

TECHNICAL DATA:

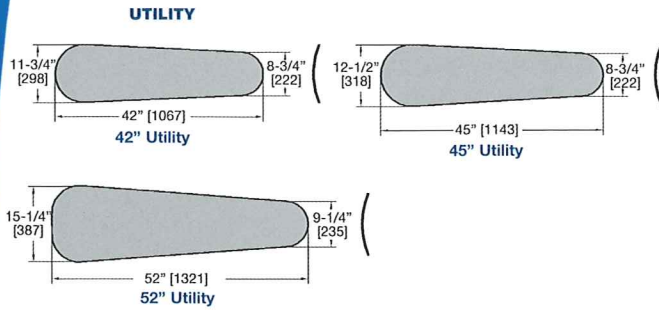

- A** 49 5/16" [1252]
- B** 42" [1067]
- C** Dimension "C"
(see table below)

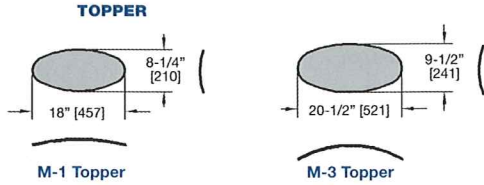
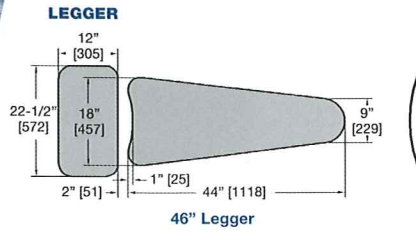
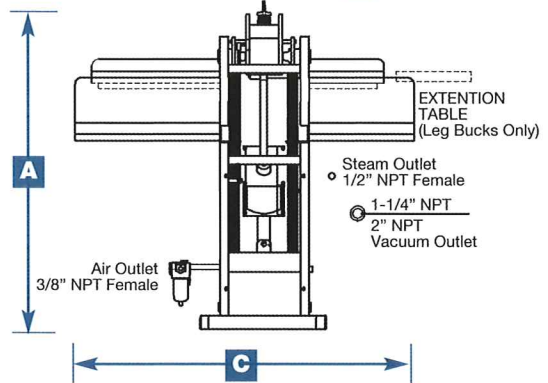
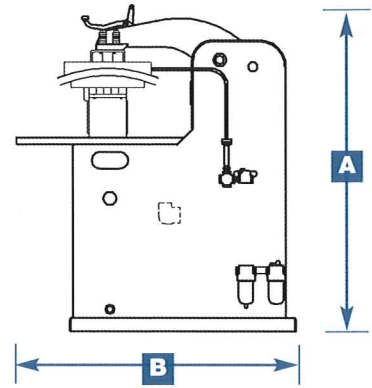

TECHNICAL SPECIFICATIONS:

	SLUCA 46	SLUAM-1	SLUAM-3
Steam Consumption @ 80 psig	30 lb/hr [13.6 kg/hr]	22 lb/hr [10 kg/hr]	22 lb/hr [10 kg/hr]
Max. Steam Pressure	125 psi [862 KPa]	125 psi [862 KPa]	125 psi [862 KPa]
Air Consumption Free Air per Cycle @ 80 psi	0.69 ft ³ [0.02 M ³]	0.69 ft ³ [0.02 M ³]	0.69 ft ³ [0.02 M ³]
Max. Air Pressure	80 psi [552 KPa]	80 psi [552 KPa]	80 psi [552 KPa]
Vacuum Size - NPT Female	1-1/4" (Utilities); 2" (Leggers)	1-1/4" (Utilities); 2" (Leggers)	1-1/4" (Utilities); 2" (Leggers)
Voltage	120/220	120/220	120/220
Table Length - Dim. "C"	48 in [1219 mm]	21 in [533 mm]	21 in [533 mm]
Net Machine Weight	845 lb [382 kg]	690 lb [314 kg]	700 lb [318 kg]
Shipping Weight	895 lb [407kg]	740 lb [336 kg]	750 lb [340 kg]
	SLUA 42	SLUA 45	SLUA 52
Steam Consumption @ 80 psig	30 lb/hr [13.6 kg/hr]	30 lb/hr [13.6 kg/hr]	30 lb/hr [13.6 kg/hr]
Max. Steam Pressure	125 psi [862 KPa]	125 psi [862 KPa]	125 psi [862 KPa]
Air Consumption Free Air per Cycle @ 80 psi	0.69 ft ³ [0.02 M ³]	0.69 ft ³ [0.02 M ³]	0.69 ft ³ [0.02 M ³]
Max. Air Pressure	80 psi [552 KPa]	80 psi [552 KPa]	80 psi [552 KPa]
Vacuum Size - NPT Female	1-1/4" (Utilities); 2" (Leggers)	1-1/4" (Utilities); 2" (Leggers)	1-1/4" (Utilities); 2" (Leggers)
Voltage	120/220	120/220	120/220
Table Length - Dim. "C"	51 in [1295 mm]	51 in [1295 mm]	60 in [1524 mm]
Net Machine Weight	810 lb [368 kg]	825 lb [375 kg]	860 lb [390 kg]
Shipping Weight	860 lb [390 kg]	875 lb [398 kg]	910 lb [413 kg]



Hoffman/New Yorker, Inc.
 46 Clinton Place Hackensack, NJ 07601 USA
 Phone: 201-488-1800 Fax: 201-488-4480
 www.hoffman-newyorker.com

DISTRIBUTED BY:

Equipment is subject to manufacturer's standard warranty. Accuracy of illustration and description of equipment shown herein applies to product as manufactured at time of publication.

© Copyright 2009, Hoffman/New Yorker, Inc. All rights reserved.
 Printed in U.S.A.

Hoffman Slim-Line Dry Cleaning Press



The new revolutionary design dry cleaning press.

INNOVATIVE FEATURES:

- Compact frame – minimal floor space
- Extremely quiet and smooth operation
- Novel, quick-disconnect pneumatic circuit module for ease of maintenance
- Energy efficient insulated head cover and steam hoses reduce utility costs and provides cooler working environment
- Automatic air timed post vacuum
- Lock with pressure or no-lock selector switch
- Ergonomic soft touch operating buttons and foot pedals for operator comfort
- Extra wide head opening provides easy access to and unrestricted view of the garment
- Heavy-duty steel frame and linkage for exceptional durability
- Separate closing and pressure cylinders for fast operation and wide pressure range
- Snag-free stainless steel table

AVAILABLE OPTIONS:

- Digital release timer, or 131 timer for release and advance vacuum
- Swing-away sleeve board with vacuum
- Steam/electric iron and lowboy
- All-steam iron
- Water spray gun and condenser
- ASME certification
- CE certification
- Steam vacuum valve
- Buck blow
- Cast aluminum head
- Left hand head and buck mounting

Optional Sleever & Iron with Stand



HOFFMAN
The First Name In Pressing